

A1 Certified Non-Combustible Room Ventilation Kit

- Used to create a protected Telescopic sleeve for straight through room ventilation
- Manufactured from: Corrosion resistant 1mm Galvanised or Zinc coated steel sheet
- Finish: Non-organic heat fused oven baked finish
- Colour: Simplis Redline Red
- Telescopic action fits wall constructions 325 to 425mm wide
- High airflow design meeting Building Regulation Part F with 90% free duct area. (Circular HVAC requires a fitting converter before the wall construction)
- Single air brick 215x70mm, Double 215 x 140mm & Triple 215 x 210mm available. Bespoke Sizes on Request
- Air brick supplied separately

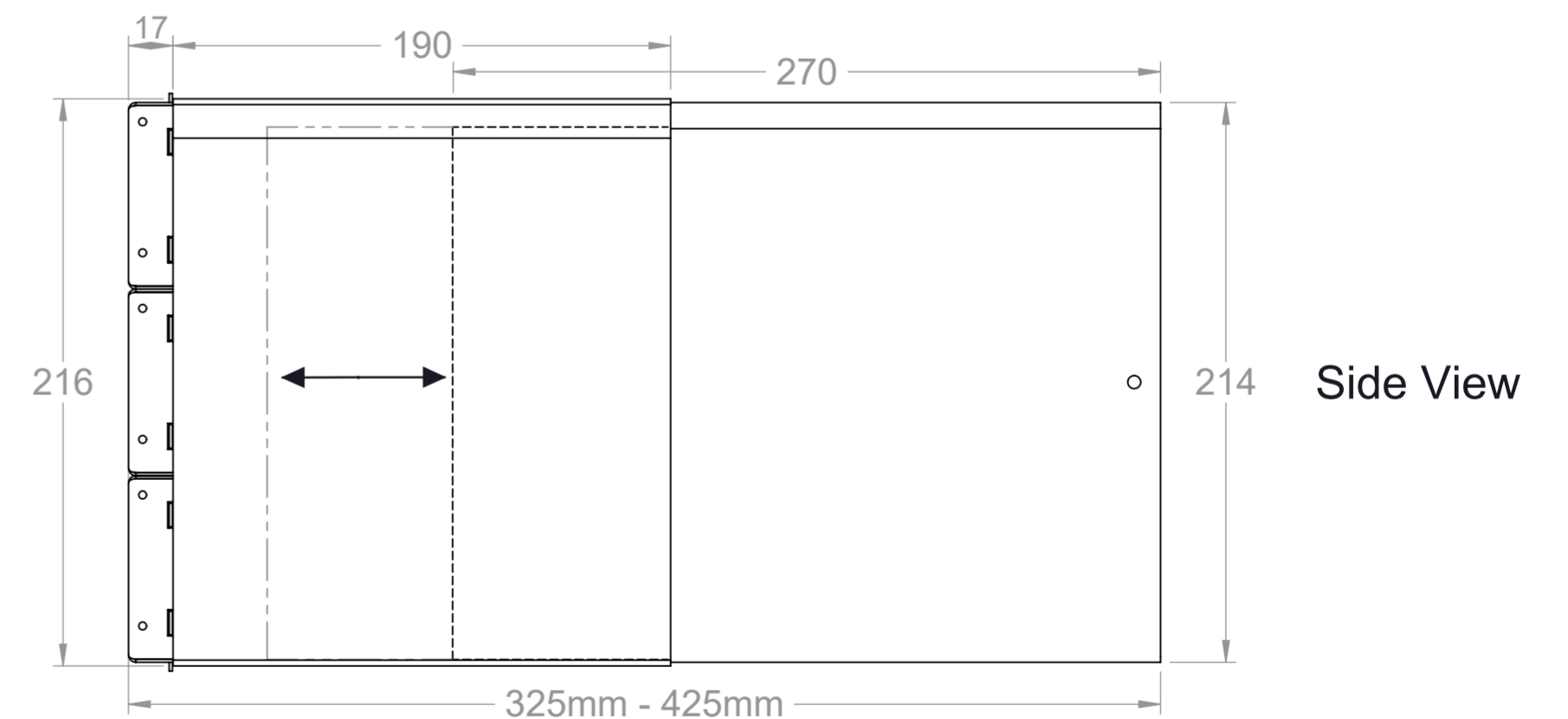
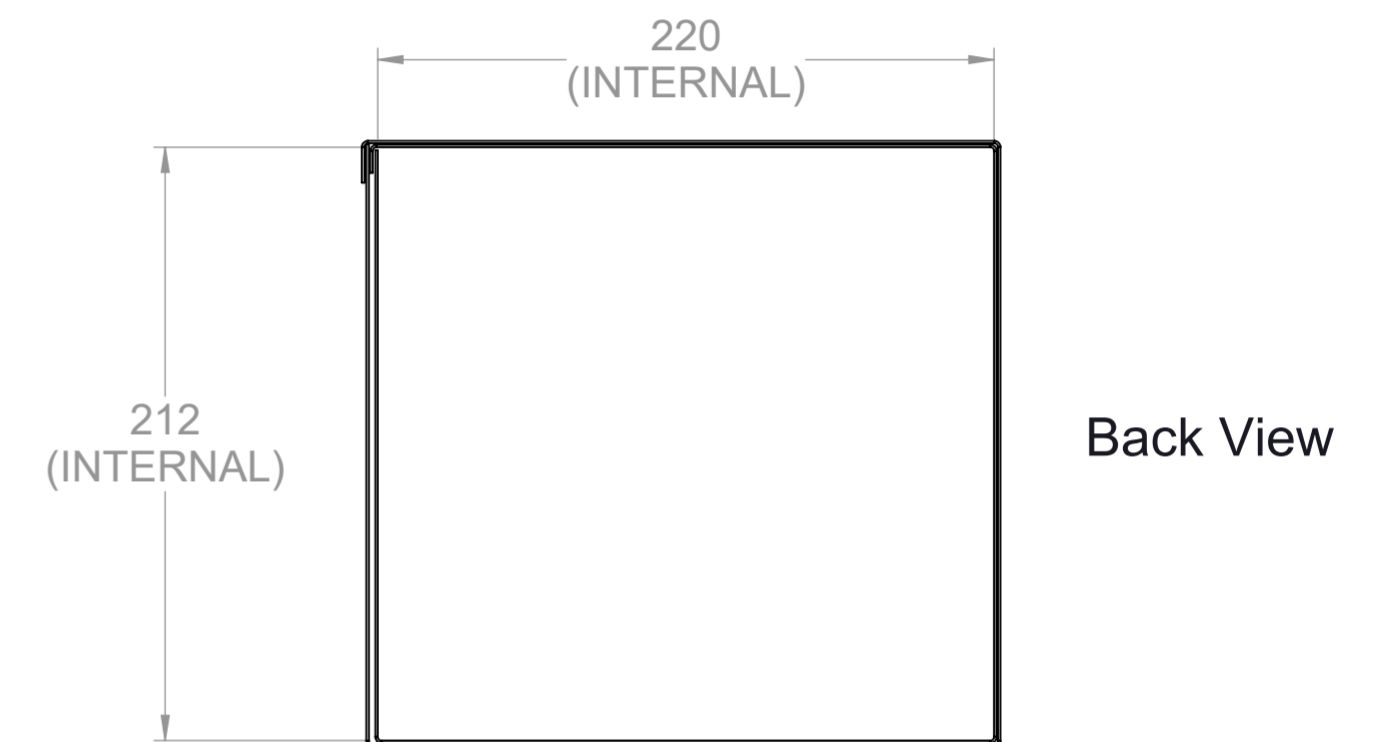
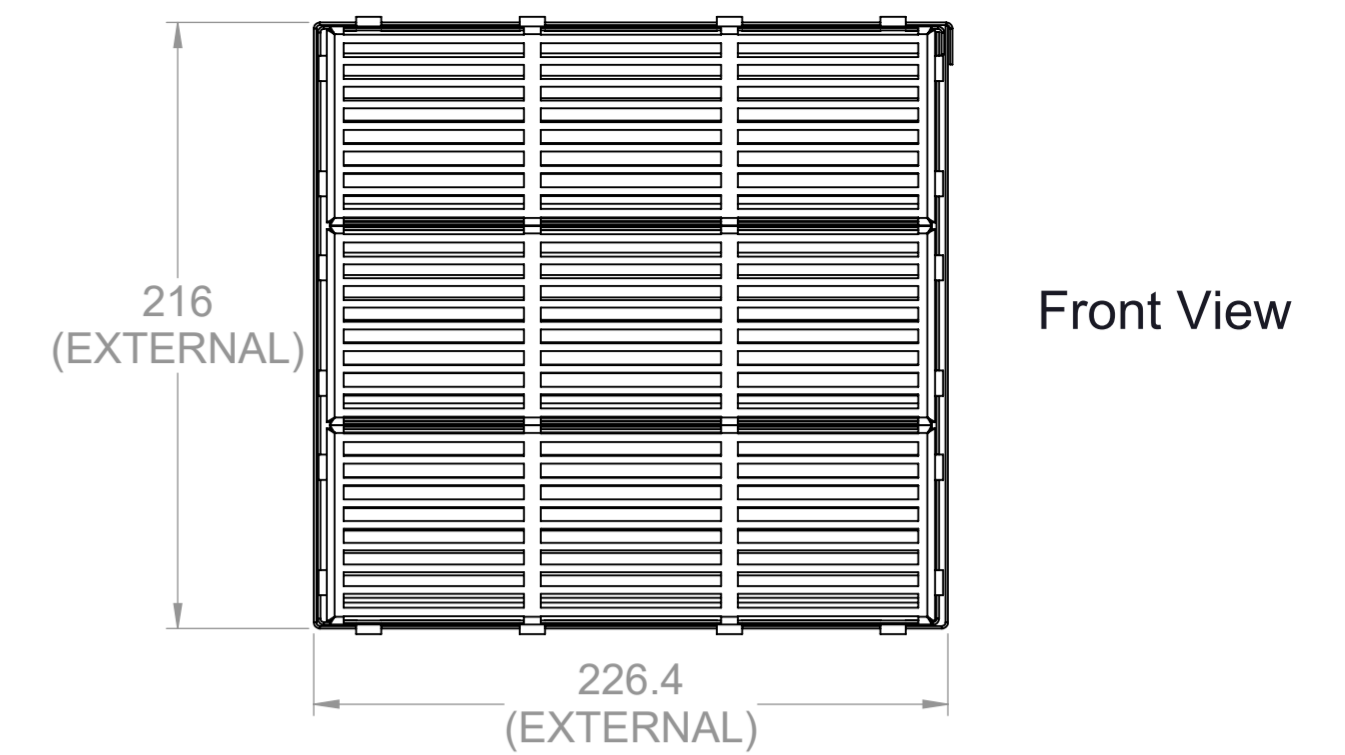
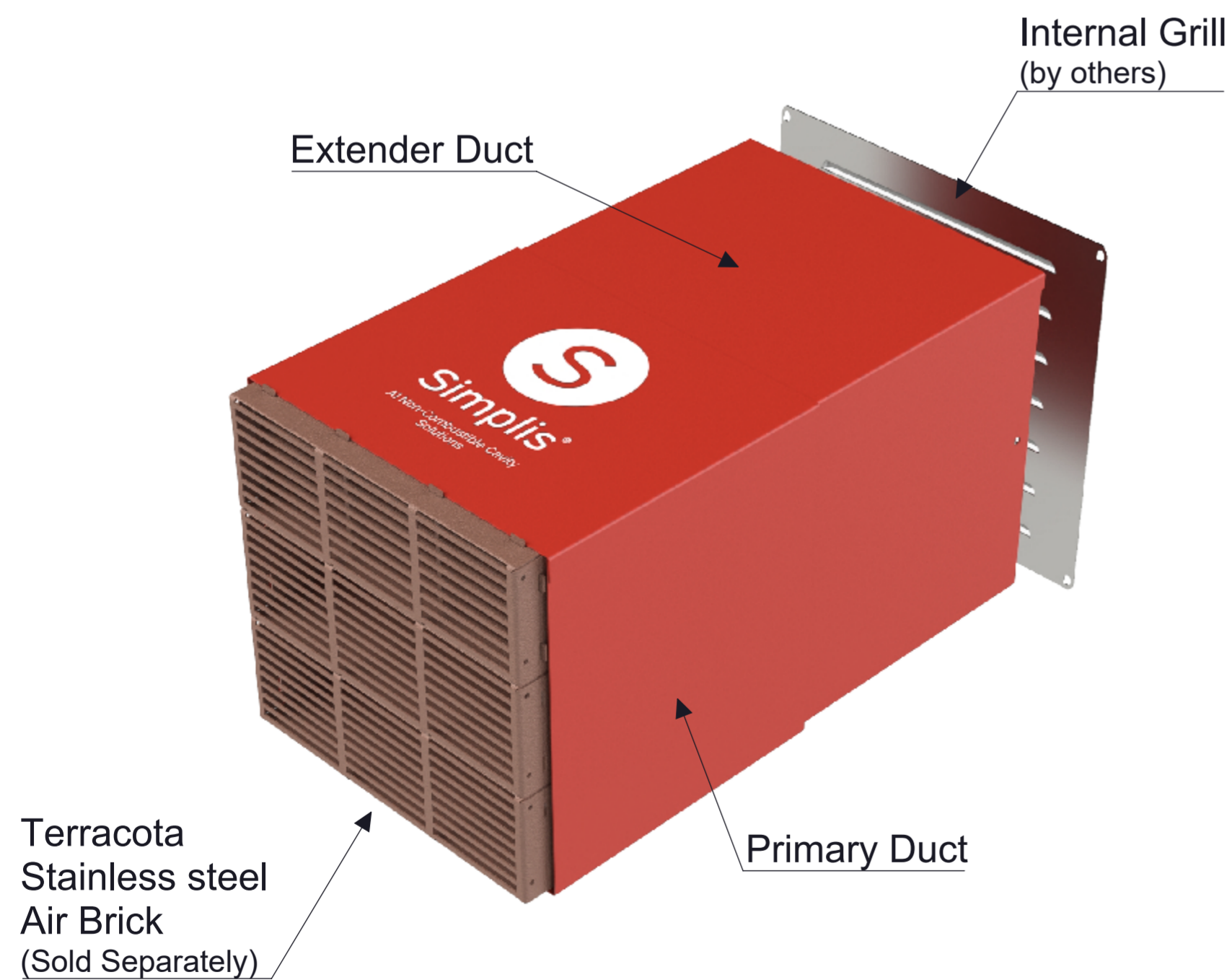

Simplis Simplifying Interior Solutions

Commercial Support
Tel : 01724 853 090
Fax : 01724 848 030
Email : support@simplis.co.uk

Title :
A1 Certified Non-Combustible
Room Ventilation Kit Triple Air Brick 215x210mm

Scale at A3:	Date:	Drawn:	Dwg No.:
	31-03-2021	SO	A1PRJW001-01-TWMA001